

Pipetite®

The Boot That Fits Like a Glove

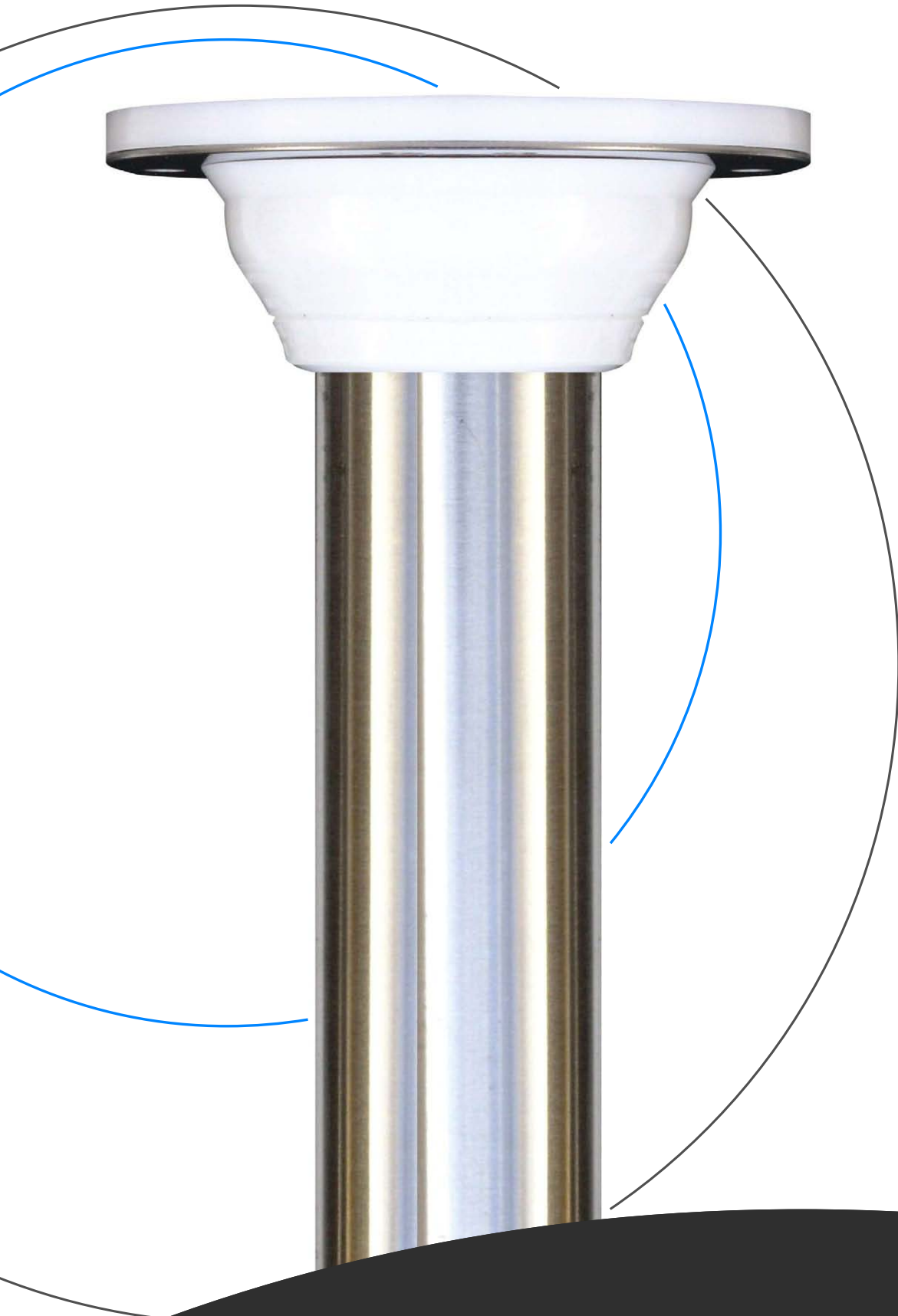

Pneumatic Grommets

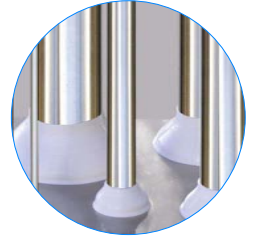

Standard Grommets

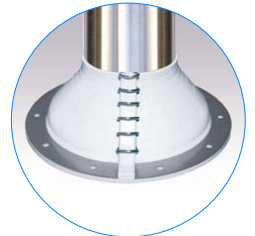

Reboot®



Standard Pipetite®



Pipe n Pipe®

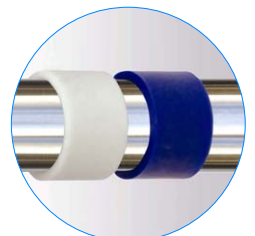

Color Code Bands



guth
SOUTH AFRICA

Pipetite®

The Boot That Fits Like a Glove

Guth SA one of the country's leading suppliers in the liquid food industry with its four strategically placed branches has added PIPETITE to its vast range of products



PIPETITE®



Pipetite unique to Guth SA has, it believes, answered the age old question “How do I seal around a pipe where it passes through a wall or ceiling panel?” What may seem like a simple problem has for many years been a source of high installation and repeated maintenance costs. Pipetite is the solution. Pipetite offers essential ability of sealing the connection whilst allowing for significant movement of the pipe. Installation is simple, the product accommodates a large number of different pipe diameters and offers long term performance while remaining cost competitive.

The design incorporates some truly unique features: Self-sealing ‘lip seals’ are incorporated into the base of the product. These seals provide permanent flexibility and remove the need to ‘pack’ the product off the wall to allow for movement. These ‘lip-seals’ also replace the need for silicon or other sealants, normally used during installation.

The contact area of the Pipetite with the pipe has been designed to be easily adapted to various pipe diameters and provide a reliable long term seal. The ‘neck’ or ‘pipe contact band’ allows the pipe to move significantly without damage occurring to the Pipetite or failure to the seal between the wall and the pipe.

- Available in five sizes to suit 5 – 180 mm tube
- Hygienic white silicon and 316 stainless steel
- Totally self-sealing – no sealant required
- No cracking of silicon
- -60° to + 260° C temperature rating
- Can be retro-fitted

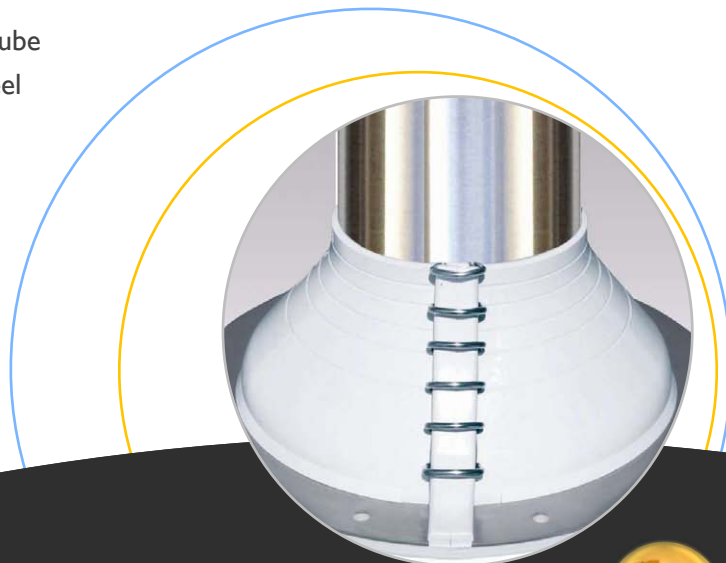

guth
SOUTH AFRICA

Contact Us



Johannesburg:

79 St Georges Street, Newlands
PO Box 58070, Newville, 2114
Phone: + 27 (0)11 477-4923
Fax: + 27 (0)11 477-8062
e-mail: jhb@guth.co.za

Cape Town:

2 Platinum Rd, Marconi Industria, Montague Gardens
PO Box 1486, Milnerton, 7435
Phone: + 27 (0)21 555-8300
Fax: + 27 (0)21 552-2228
e-mail: Cape@guth.co.za

Port Elizabeth:

Unit 24, Willow Road Business Park, 33 Willow Road, Fairview
PO Box 70496, The Bridge PO, Port Elizabeth, 6032
Phone: + 27 (0)41 367 2431
Fax: + 27 (0)41 367 5152
email: pe@guth.co.za

Pinetown:

Unit 3 Pastel Park, 50 Wareing Road
PO Box 8, Pinetown, 3600
Phone: + 27 (0)31 709-5444
Fax: + 27 (0)31 709-8333
e-mail: pinetown@guth.co.za



guth
SOUTH AFRICA